Operation Manual

Applied L-16 Series Hand Winch Lifts

- Three Section 16' Hand Winch Lift
- Certified Load: 500 lbs. at any height
- Loading Height: 6-1/2'
- Maximum Lift Height: 16'
- Footprint: 84"
- Folded Dimensions: 12.5" x 12.5" x 77"
- Weight: 95 lbs.
- Cable: 3/16" Steel



OPERATOR SAFETY INSTRUCTIONS

IMPORTANT Read and understand this instruction manual prior to operating or performing maintenance on this lift!

1. INSPECT THE EQUIPMENT

Prior to each use of the unit, check all moving parts and wire rope to ensure that they are in proper operating condition.

If a unit has visible damage or does not transfer up and down smoothly during pre-operation, **do not use the unit!**

If cable is kinked, worn, frayed, damaged, or has any debris on it that would obstruct its rotation around the pulley wheels, **do not use the unit!**



Use only Applied replacement parts. Non-OEM parts will severely compromise the quality and safety designed into this lift.

Each unit should have a complete set of caution decals and a legible Operators Manual. Contact Applied if any of these items are missing.

Do not misuse the unit. Perform only the functions for which the unit is designed. Never attempt to operate the equipment at more than the recommended capacity. **DO NOT EXCEED RATED CAPACITY!**

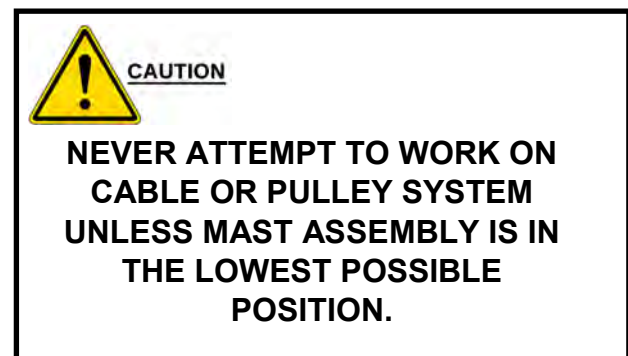
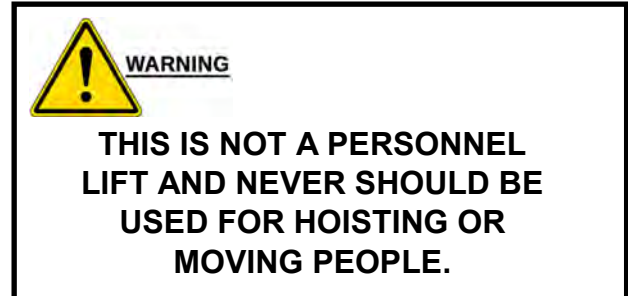

2. WORK AREA HAZARDS

Never operate during high wind conditions. Lifting loads during high winds can result in the lift tipping over and the possibility of operator injury.

Operate only on level surfaces. Use the unit on smooth and level surfaces to avoid unit tipping over and the possibility of operator injury. Do not operate from an unstable platform.

Always watch for and avoid overhead wires and obstructions when using the unit or moving unit to and from the event site.

Do not use unit to support ladders, for climbing, hoisting or people moving.

Do not use unit outside in thunder, lightning or severe weather.

ASSEMBLING THE LIFT

1. WINCH INSTALLATION

The L-16 lift and winch assembly are packaged separately. The lift is shipped with the steel cable installed. Take care when removing the winch from the carton as the lift leveling feet and other small parts are packaged with the winch.

Attach winch to the platform mounting channel using (3) 3/8" x 1-1/4" bolts provided. See **Figure 1**

Figure 1

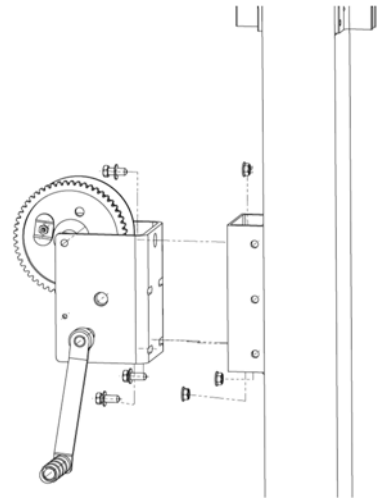

2. WINCH CABLE ATTACHMENT

Wrap at least two turns of cable around the drum of the winch.

Feed at least 5" of cable through the hole on the right side of winch drum, same side as the handle.

With your thumb, bend a loop in the cable, as illustrated.

Loosen the capture nut and carefully feed the loop through the catch and tighten the capture nut with a wrench.

See **Figures 2 & 3**

Figure 2

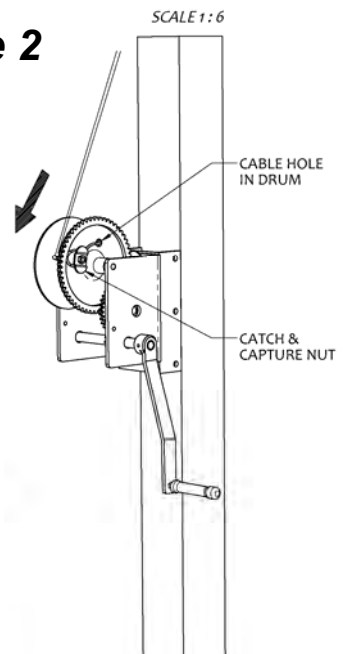

Figure 3



3. LEG ASSEMBLY

Install leveling feet to the bottom of each fold-out leg, threading the leveling foot into the threaded insert. Press the black plastic cap into the end of the leg tube.

See **Figure 4**

Figure 4

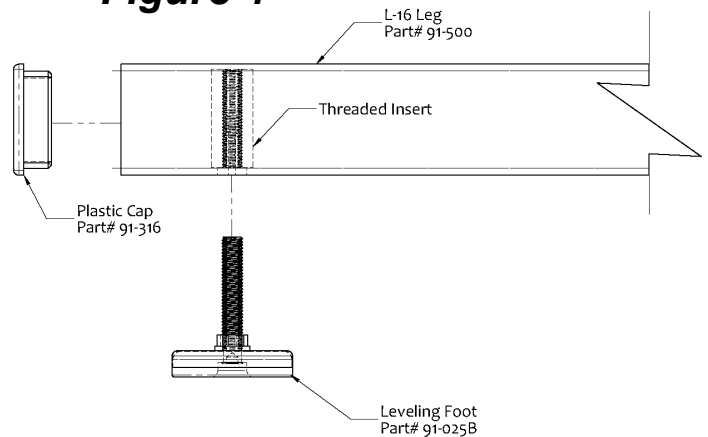

OPERATING PROCEDURE

Remove locking pin holding each leg in the folded position. Fold the legs down and re-insert locking pins through the leg braces.

The central mast is the main load supporting element.

Adjust the leveling feet at the end of each leg so that the lift is vertically straight and level. Make sure to eliminate any slack between the legs and braces.

When used indoors, leveling feet should be adjusted so that the central mast rests solidly on the floor.

When used outdoors, leg feet MUST be supported to prevent sinking that could cause lift to tip. Plywood pads or other solid material must be used to assist in the leveling of the lift. Supports must be stable.

Inspect the cable to make sure that none of the wires are frayed or that the cable itself has not been crushed.

Test the lift to see that no damage has been incurred that would bind the moving pieces of the system.

Be sure to secure the load to the lift with proper hardware.

If multiple lifts are being used simultaneously, all lifts must be raised evenly.

Three safety pins are provided for use when raising and lowering the lift. These must be used to insure safety in the event of cable failure. As you raise the lift, insert a safety pin into the first hole in the 2" tube. Then insert a 2nd pin into the next hole down as it becomes visible. When the 3rd hole becomes available, remove the first safety pin and insert it into the 3rd hole. Continue to alternate pins through the holes until the second stage begins to rise. Leave a pin in the last hold of the 2" tube. Using the two remaining pins, repeat the above procedure inserting pins in the 3" tube for lifts above 12 ft. To lower the system, follow the above procedures in reverse order.

NOTE: Make sure that the winch is ratcheting as you turn the winch handle. If this fails to happen, lower the lift slightly and then raise it again until you hear it click before releasing the handle. If this occurs, the winch may need to be adjusted internally.

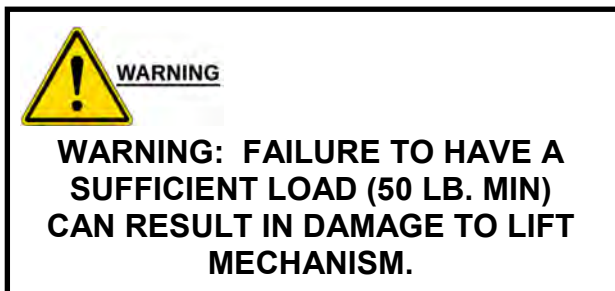

LIFT MAINTENANCE

The steel cable deserves and requires the most attention as it is the means by which the load is able to move up and down. The proper cable for this application is supplied, but it is up to you to inspect and maintain it regularly.

Keep the cable lubricated periodically to avoid oxidation. Any light duty oil or silicone based lubricant will do just fine.

Lubricate the pulleys frequently to prevent premature wear. The same lubricant used on the cable will be sufficient for this application.

If the cable shows any sign of fraying, wear, or deformation – order a replacement from your authorized Applied Electronics dealer or distributor.

Inspect the ball and shank that is swaged to the top of the cable. As of 2019, all cables have a secondary safety swag at the end of the cable. Note the cable should always remain flush to the end of the safety swag. The secondary safety swag should NOT be in contact with the ball and shank swag. If there is no gap between the safety swag and the ball and shank, or if the cable is not flush with the safety swag, remove the lift from service.

Always replace any bent or broken parts immediately. These parts are available and should be purchased through the Applied Electronics dealer network.

Individually push the 2" and the 3" tubes to one side in both directions and check the gap between the tube and the bushing material that surrounds the tube at the top of each larger tube. If the gap ever becomes greater than .035", then new material should be ordered to replace the worn material. This gap can be measured quickly and effectively with a standard feeler gauge.

To replace the cable, follow the cable routing diagram in **Figure 5**. Be sure to keep the tubes in the same alignment orientation. Termination of the cable to the winch should be done as shown in **Figure 6**.

Do not oil or grease winch brake mechanism.

CABLE ROUTING

Figure 5

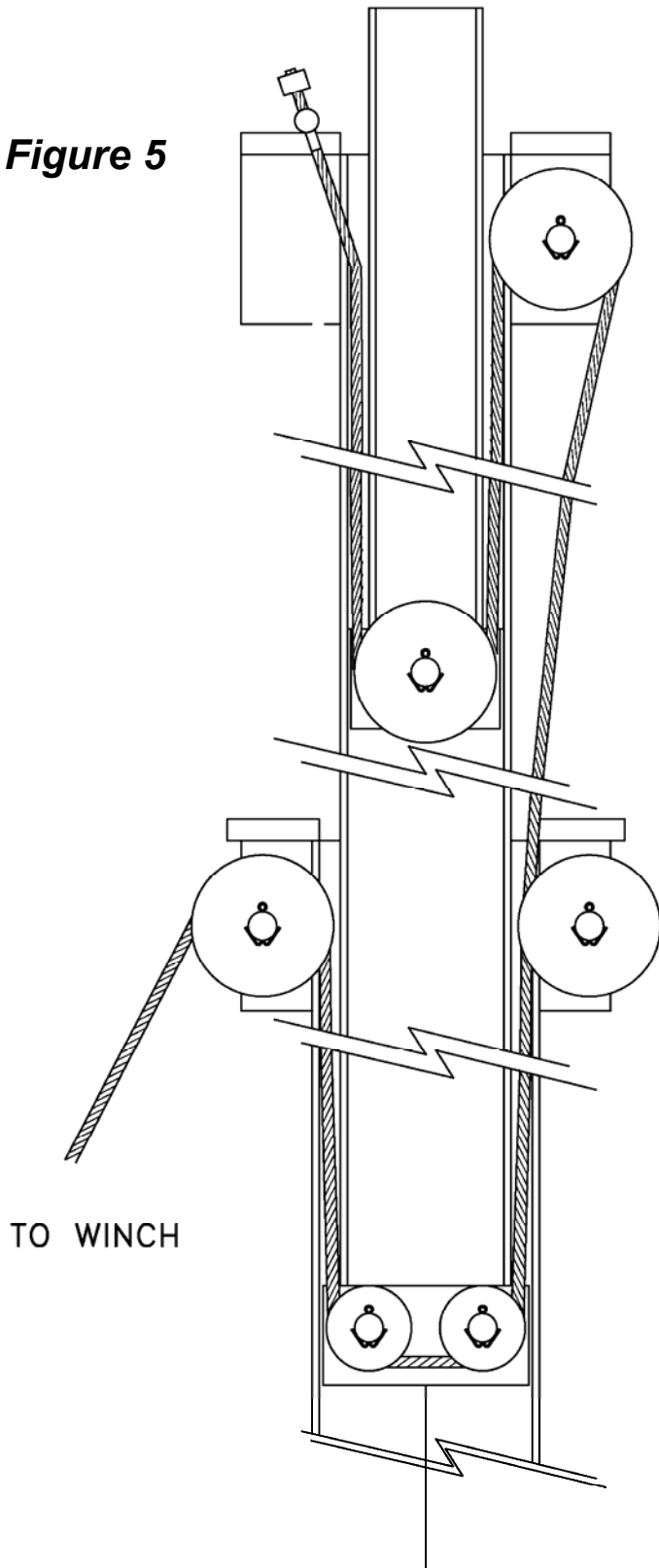
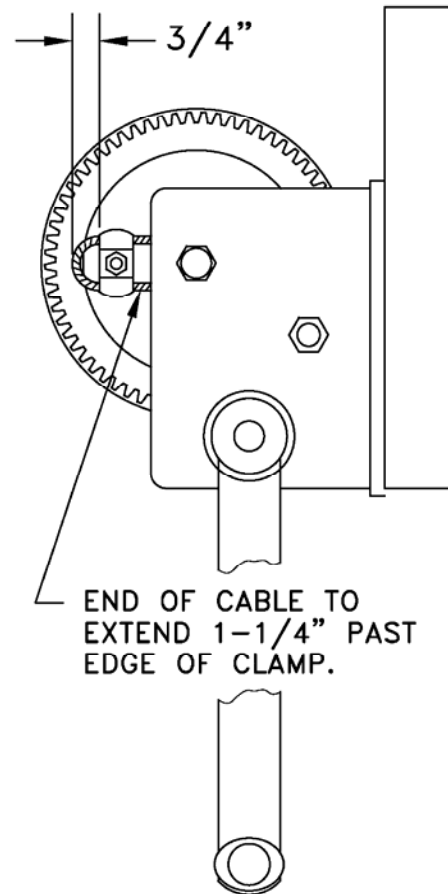
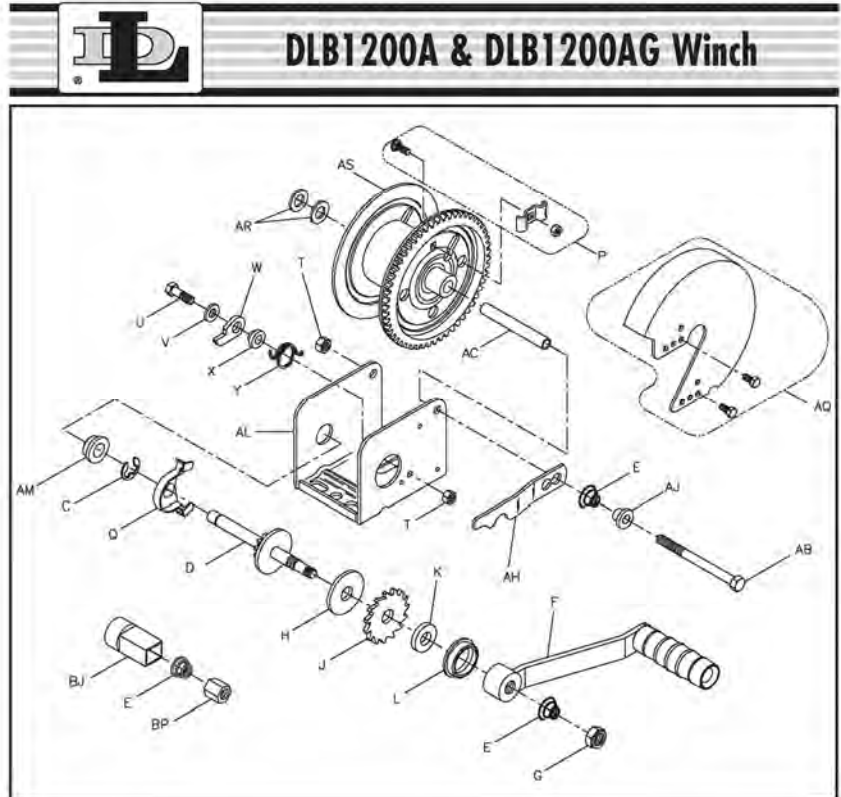

Figure 6



WINCH PARTS BREAKDOWN

| ITEM NO. | DESCRIPTION | PART NO. |
|----------|------------------------|----------|
| A | Base | 404900 |
| B | Bushing | 204012 |
| C | "E" Ring | 205116 |
| D | Drive Shaft | 306061 |
| E | Spring | 204364 |
| F | Handle 7" | 5703061 |
| G | Nut | 205033 |
| H | Pressure Plate | 204362 |
| J | Ratchet Wheel | 404164 |
| K | Pressure Washer | 404163 |
| L | Bushing | 206328 |
| M | Nut | 205316 |
| N | Bolt | 205332 |
| P | Rope Clamp Kit | 5243506 |
| Q | Gear Cover "G" Series | 406114 |
| S | Reel | 306075 |
| T | Locknut | 204803 |
| U | Bolt | 205167 |
| V | Flat Washer | 205055 |
| W | Pawl | 404166 |
| X | Spacer | 404166 |
| Y | Spring | 204363 |
| Z | Reel Spacer | 207183 |
| AB | Bolt | 203161 |
| AC | Reel Spacer | 204807 |
| AH | Lockout Lever optional | 404579 |
| AJ | Spacer optional | 404166 |
| AL | Base | 404896 |
| AM | Bushing | 204009 |
| AQ | Gear Cover optional | 5240122 |
| AR | Spacer Washer | 204360 |
| AS | Reel | 304754 |
| BJ | Drive Hub optional | 304562 |
| BP | Special Nut optional | 404970 |



L-16 REPLACEMENT PARTS

L-16 TOP MAST PARTS SHEET

UPPER SECTION

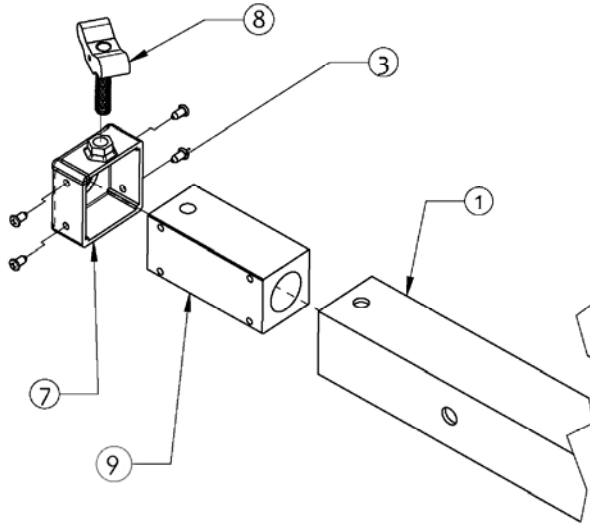

LOWER SECTION

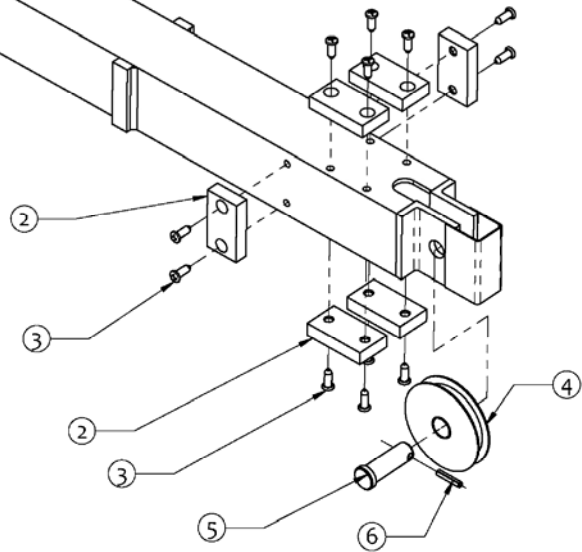

| ITEM NO. | DESCRIPTION | SIZE | REFER. NO. | QTY |
|----------|----------------------------|-------------------------|------------|-----|
| 1 | L-16 2" Mast | Top Mast | 90-112 | 1 |
| 2 | Lower Bushing | 3/8" x 1-3/4" | 91-334 | 6 |
| 3 | Sheet Metal Screw | #8 x 1/2" | 91-066 | 16 |
| 4 | Cable Pulleys | 2-1/2" | 91-024 | 1 |
| 5 | Pin - Clevis | 1/2" x 1-1/2" | 91-310 | 1 |
| 6 | Pin - Slotted Roll | 5/32" x 3/4" | 91-304 | 2 |
| 7 | L-16 Steel Lock Collar | Sheet Metal Part | 96-000 | 1 |
| 8 | L-16 Thumbscrew | 3/8"-16 x 1-1/4" | 91-328 | 1 |
| 9 | Top Plastic Insert | Machined Square HDPE 4" | 91-039 | 1 |
| 10 | L-16 Old Style Mast Insert | Lifts Mfg Prior to 2011 | 92-503 | 1 |

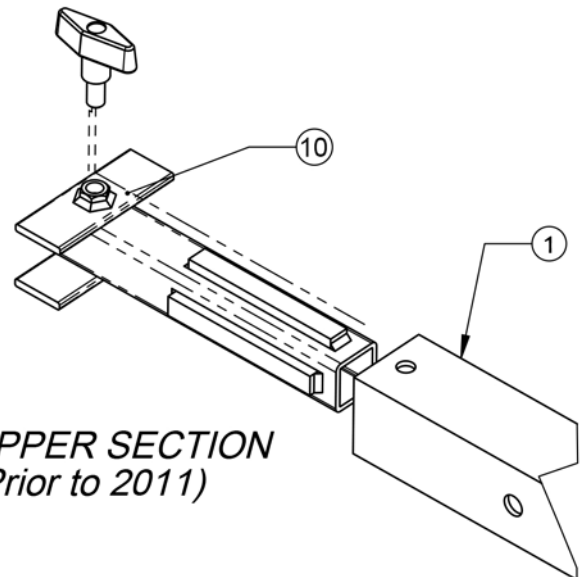

UPPER SECTION (Prior to 2011)

L-16 REPLACEMENT PARTS

L-16 MIDDLE MAST PARTS SHEET

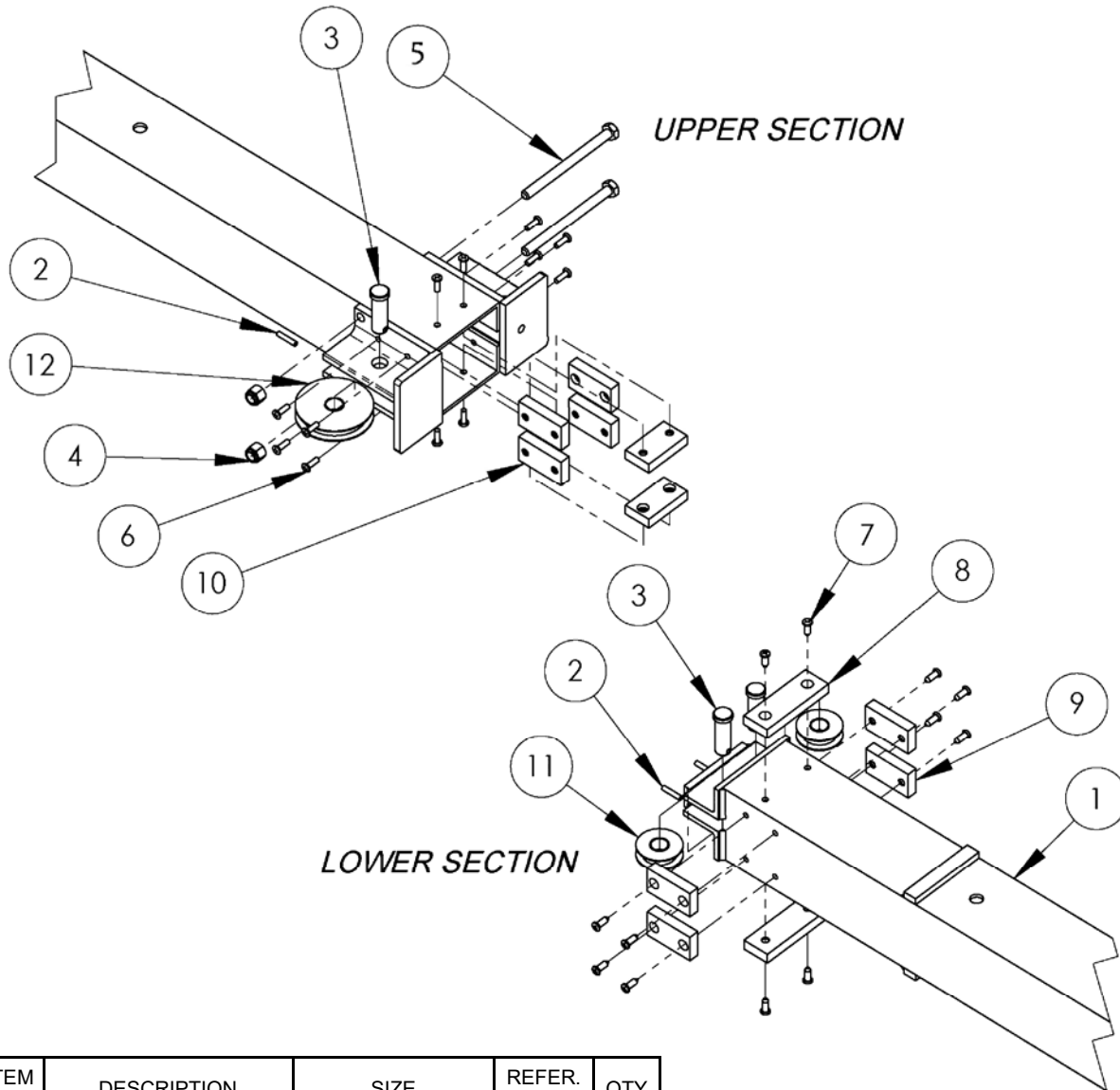

| ITEM NO. | DESCRIPTION | SIZE | REFER. NO. | QTY |
|----------|------------------------|----------------------|------------|-----|
| 1 | L-16 3" Mast | Middle Mast | 90-113 | 1 |
| 2 | Pin - Slotted Roll | 5/32" x 3/4" | 91-304 | 3 |
| 3 | Pin - Clevis | 1/2" x 1-1/2" | 91-310 | 3 |
| 4 | SAE Hex Nut - Nylock | 5/16"-18 Thread | 91-063 | 2 |
| 5 | SAE Hex Cap Bolt | 5/16"-18 x 4" Grd 5 | 91-081 | 2 |
| 6 | Machine Screw | #8-32 x 5/8" Lg Zinc | 91-074 | 12 |
| 7 | Sheet Metal Screw | #8 x 1/2" Lg Zinc | 91-066 | 12 |
| 8 | Lower Bushing | 3/8" Width 2-7/8" | 91-335 | 2 |
| 9 | Lower Bushing | 3/8" Width 1-7/8" | 91-334 | 4 |
| 10 | Upper Bushing with Nut | 3/8" Width 1-7/8" | 91-336 | 6 |
| 11 | Cable Pulleys | 1-1/2" Lg | 91-023 | 2 |
| 12 | Cable Pulleys | 2-1/2" Lg | 91-024 | 1 |

L-16 REPLACEMENT PARTS

L-16 BOTTOM MAST PARTS SHEET

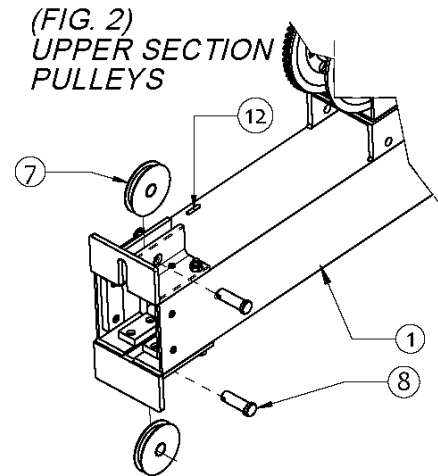
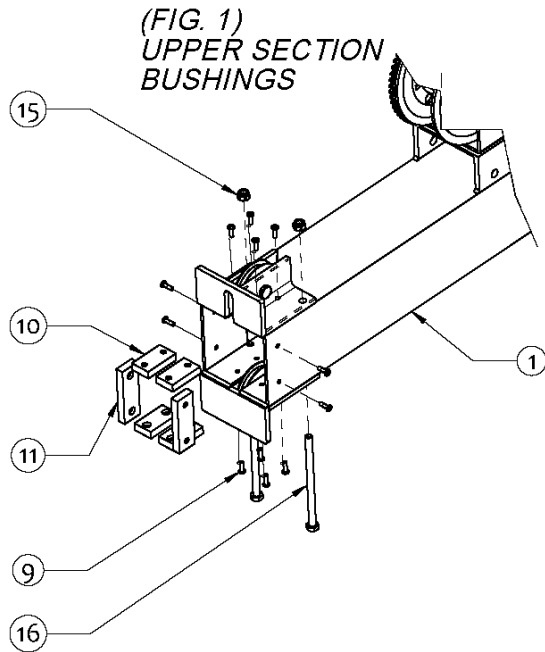

| ITEM NO. | DESCRIPTION | SIZE | REFER. NO. | QTY |
|----------|--------------------------|--|------------|-----|
| 1 | L-16 4" Mast | Bottom Mast | 90-114 | 1 |
| 2 | L-16 Leg | Leg Assembly | 92-500 | 4 |
| 3 | L-16 Outrigger | Leg Brace/Outrigger | 92-501 | 4 |
| 4 | L-16 Threaded Leg Insert | 1-3/4" x 1-3/4" x 3/4" | 92-504 | 4 |
| 5 | L-16 Screw Foot | 3/8"-16 Threaded Leveler | 91-025b | 4 |
| 6 | Leg Pin - T-Handle | 3/8" x 3-1/2" | 91-300 | 4 |
| 7 | Cable Pulley | 2-1/2" Lg | 91-023 | 2 |
| 8 | Pin - Clevis | 1/2" x 1-1/2" Lg | 91-310 | 2 |
| 9 | Machine Screw | #8-32 x 5/8" Lg | 91-074 | 12 |
| 10 | Upper Bushing with Nut | 3/8" Width 1-7/8" | 91-336 | 4 |
| 11 | Upper Bushing with Nut | 3/8" Width 2-7/8" | 91-337 | 2 |
| 12 | Pin - Slotted Roll | 5/32" x 3/4" Pin | 91-304 | 2 |
| 13 | Winch | DLB1200A | 92-505 | 1 |
| 14 | SAE Hex Cap Bolt | 3/8"-16 x 3.5" Grd 8 | 92-078 | 7 |
| 15 | SAE Hex Nut - Nylock | 3/8"-16 Thread | 91-060 | 8 |
| 16 | SAE Hex Cap Bolt | 5/16"-18 x 5" Grd 5 | 91-082 | 2 |
| 17 | Caster Wheel Sleeve | 1/2" Dia x 1-1/2" | 91-610 | 2 |
| 18 | Caster Wheel | 3/8" x 1-1/4" | 91-601 | 2 |
| 19 | Flat Washer | 3/8" Standard Flat Washer | 91-010 | 2 |
| 20 | Plastic Tube Cap | 2" Square Cap - Black | 91-317 | 4 |
| 21 | Flat Washer | 3/8" Stainless Steel Thin | 91-012 | 16 |
| 22 | SAE Hex Cap Bolt | 3/8"-16 x 6-1/2" Grd 8 | 91-068 | 1 |
| 23 | SAE Hex Nut - Nylock | 3/8"-16 Thread | 91-060 | 1 |
| 24 | Plastic Tube Cap | 1-1/2" x 2" Cap - Black | 91-316 | 4 |
| | Wheel Kit | 2 Wheels, 2 Wheel Sleeves, Axle and Hdwr | 91-022 | 1 |
| | Cable Assembly | 3/16" x 28', 7x19 GAC w/ Ball & Shank | 91-501 | 1 |
| | Warning Label | Warning Label | 92-103 | 1 |
| | Caution Label | Caution Label | 92-104 | 1 |
| | Safety/Mast Pin | 3/8" x 4-1/2" Quick Release | 91-301 | 3 |

L-16 LEG RETROFIT KIT ONLY 91-026A

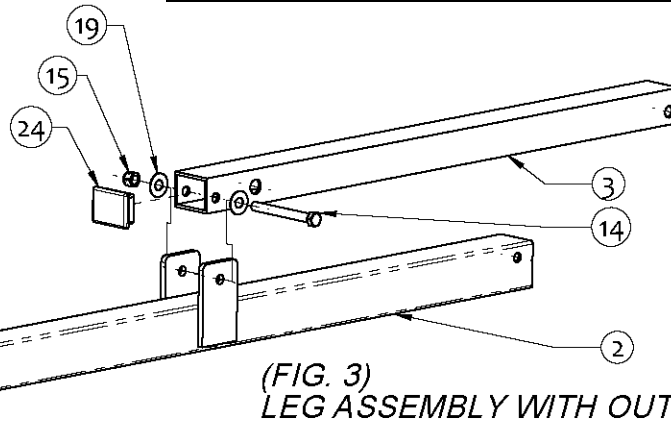
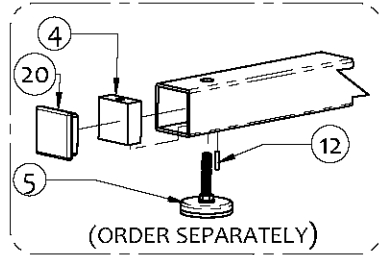

L-16 REPLACEMENT PARTS

L-16 BOTTOM MAST PARTS SHEET continued

(FIG. 4)
ATTACHING LOWER WHEELS

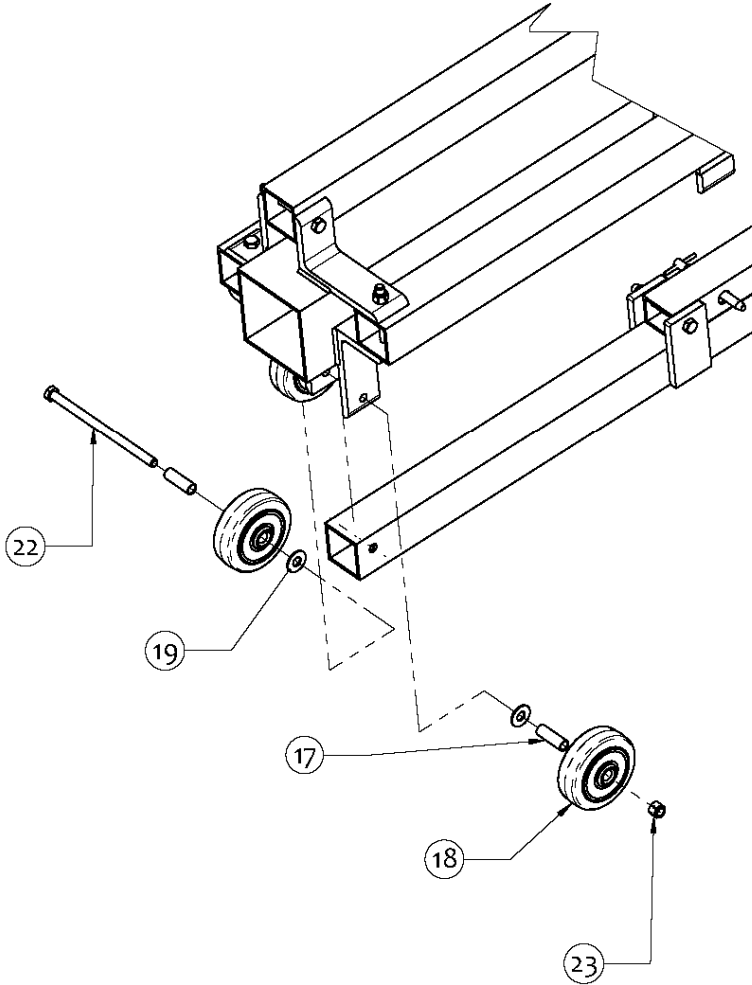

(FIG. 5)
ATTACH LEG ASSEMBLIES

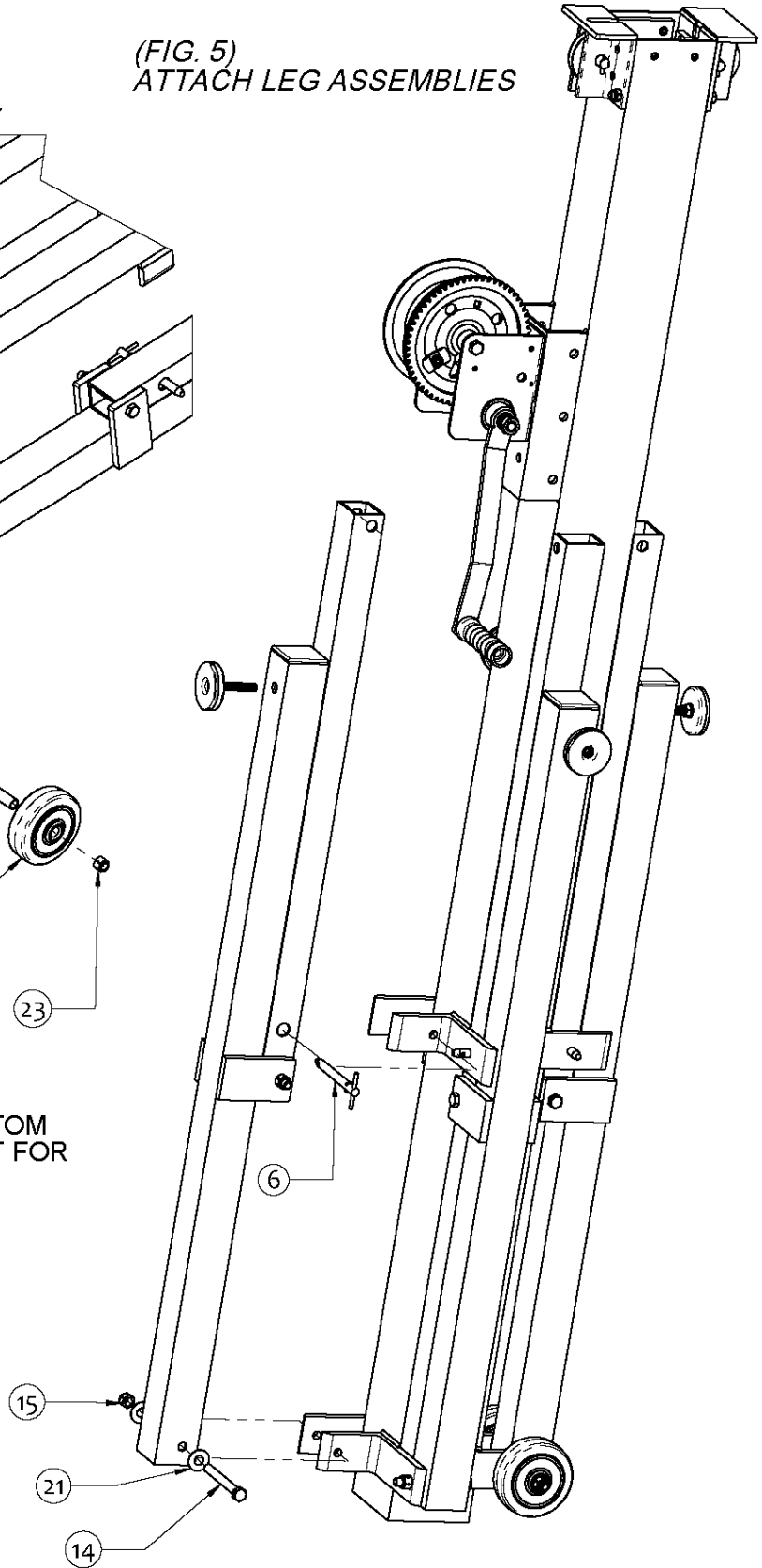

NOTES:

1) EACH LEG ATTACHES TO THE BOTTOM MAST (FIG 5) THE SAME WAY, EXCEPT FOR THE LEG WITH WHEELS (FIG 4) WHICH IS OPPOSITE THE WINCH.

L-16 HAND WINCH LIFT DETAIL

