

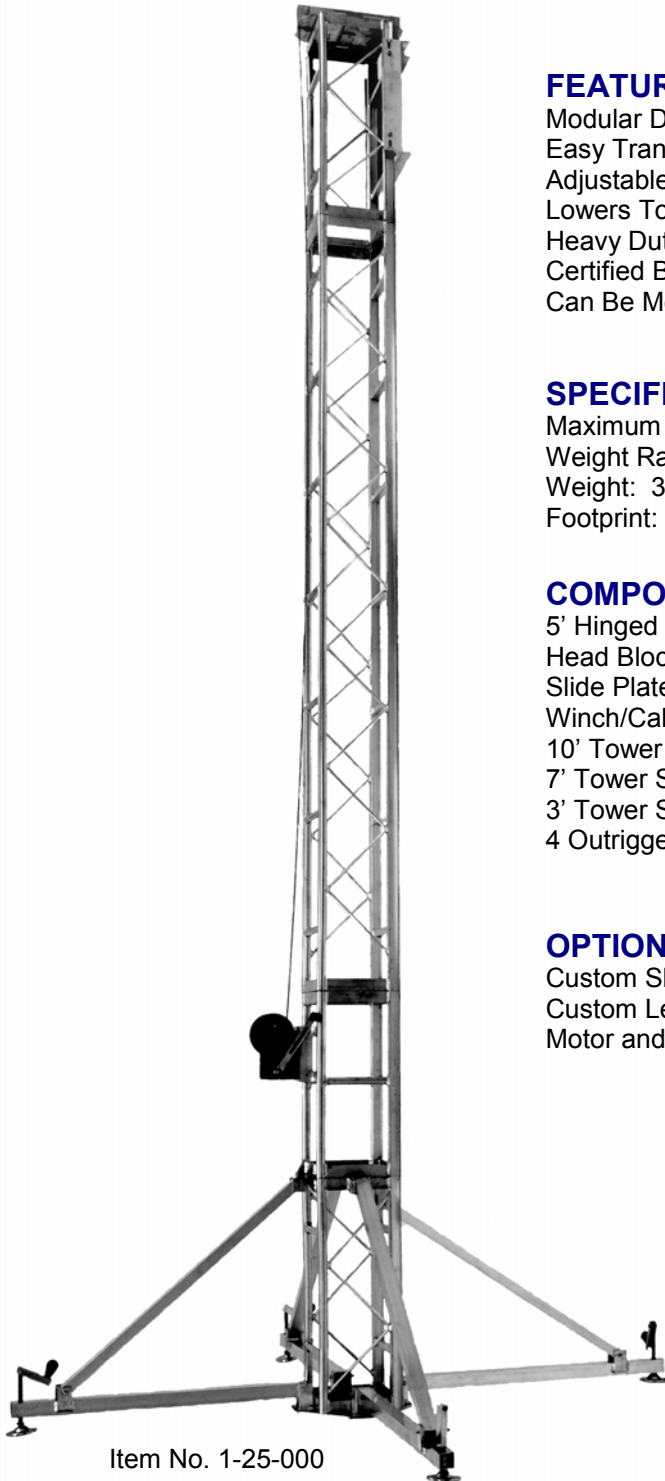

The Mini Tower can provide support for roof systems and lighting grids within the load limits of the tower. The modular all aluminum design allows for fast assembly and easy loading. The tower can be modified with custom sleeve blocks for 20.5" box and 18" tri truss. A CM motor package is available for the mini tower.



Item No. 1-25-000

FEATURES

- Modular Design For Fast Assembly
- Easy Transport
- Adjustable Leveling Pads
- Lowers To Ground For Easy Loading
- Heavy Duty Hand Crank Winch
- Certified By Structural Engineer
- Can Be Motorized

SPECIFICATIONS

- Maximum Height: 25'
- Weight Rating: 1200 lbs.
- Weight: 340 lbs.
- Footprint: 99"

COMPONENTS

- 5' Hinged Base Section
- Head Block
- Slide Plate
- Winch/Cable
- 10' Tower Section
- 7' Tower Section
- 3' Tower Section
- 4 Outriggers

SLIDE PLATE STANDARD BOLT HOLE PATTERNS

- 12" Lite Duty Box
- 12" Euro Box
- 12" AP/HD Box
- 14" Tri (Apex Up or Down)
- 15" x 23.5" PRT

OPTIONS

- Custom Slide Plates
- Custom Length Tower Sections
- Motor and Control Package

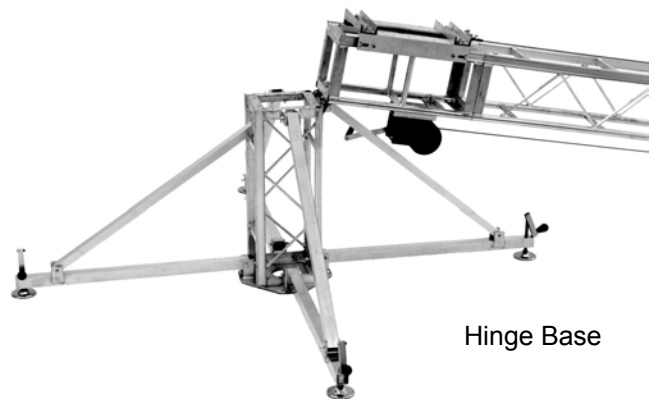

Hinge Base