

L-25 CRANK-UP MINI TOWER

L-25 MINI TOWER FEATURES

25' Maximum Height
Modular Design For Fast Assembly
Easy Transport
Adjustable Leveling Pads
Lowers To Ground For Easy Loading
Heavy Duty Hand Crank Winch
Can Be Motorized

L-25 SPECIFICATIONS

Parts Breakdown:
5' Hinged Base Section
Head Block
Slide Block
Winch/Cable
10' Tower Section
7' Tower Section
3' Tower Section
4 Legs/Outriggers
4 Leg/Outrigger Braces
Custom Length Tower Sections Available
Weight: 340 lbs.
Footprint: 99"
Part Number: 1-25-000

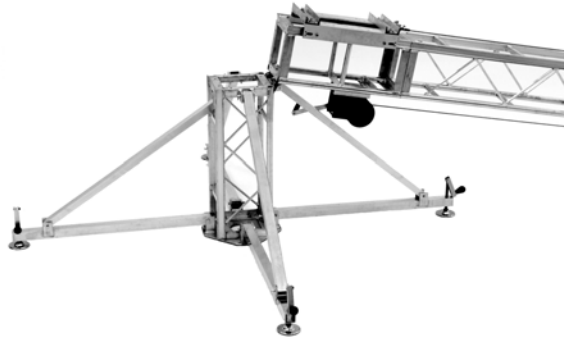

L-25 AVAILABLE ACCESSORIES

Slide Blocks Available For:
Box Truss
Triangle Truss
Single and Double Hung Club Truss

L-25 WEIGHT LOADING INFORMATION

Maximum Weight Rating: 1200 lbs. At Any Height
Weight Loading Certified By Structural Engineering Firm

